

DWG REF	QTY	PART NUMBER	DESCRIPTION	MATERIAL
<b>SHELL</b>				
1*	1	17240	SHELL	Filament Wound Epoxy/Glass composites - Head locking grooves integrally wound in place.
2*	2	96327	3" Feed Port	SA-995 CD3MW/CuN (UNS J93380)
3	2	196141	3" Port Seal	Sq-Seal - EPDM
4*	1	17180	1" FNPT Port	SA-995 CD3MW/CuN (UNS J93380)
5	1	45340	1" Port Seal	Sq-Seal - EPDM
<b>HEAD</b>				
6	1	17433	1/4" FNPT Air Vent Port	SA-479 UNS S32760
7	2	196208	1/4" Air Vent Port Seal	O - Ring - EPDM
8	1	194938	Bearing Plate Assembly Handle end	
8.1*	1	17179	Bearing Plate Handle end	SB-221 A96061-T6
8.2	1	17442	Danger label Handle end	-
9	1	117007	Sealing Plate Handle end	Engineering Thermoplastic - Noryl
10	1	194939	Bearing Plate Assembly Product end	
10.1*	1	17416	Bearing Plate Product end	SB-221 A96061-T6
10.2	1	17421	Danger label Product end	-
11	1	17126	Sealing Plate Product end	Engineering Thermoplastic - PVC*
12	1	17441	3" Product Port	SA-995 CD3MW/CuN (UNS J93380)
13.1	1	17444	Product Port Adapter	SA-995 CD3MW/CuN (UNS J93380)
13.2	1	17435	Product port holding pin	Engineering Thermoplastic
14	2	17164	Seal for Product Port Adapter	O - Ring-EPDM
15	1	17127	Product Port Retainer Ring	SA-479 316
16	2	196223	Head Seal	O - Ring - EPDM
17	1	17128	Product Port Seal	O - Ring - EPDM
18	1	17104	Handle Assembly	SA-479 316
19	1	45247	Plug Retainer Ring	Stainless Steel
20	1	17132	Plug	Engineering Thermoplastic - PVC*
21	1	196215	Plug seal	O - Ring - EPDM
<b>HEAD INTERLOCK</b>				
22*	2	47336	Quick Release Retaining Ring	SA-479 316
<b>VESSEL SUPPORT</b>				
23	2	52169	Saddle	Engineering Thermoplastic
24	2	45042	Strap Assy.	304 Stainless Steel-PVC Cushion.
25	4	46265	Strap screw.	5/16-18 UNC X 2.5" Long, 304 Stainless Steel.

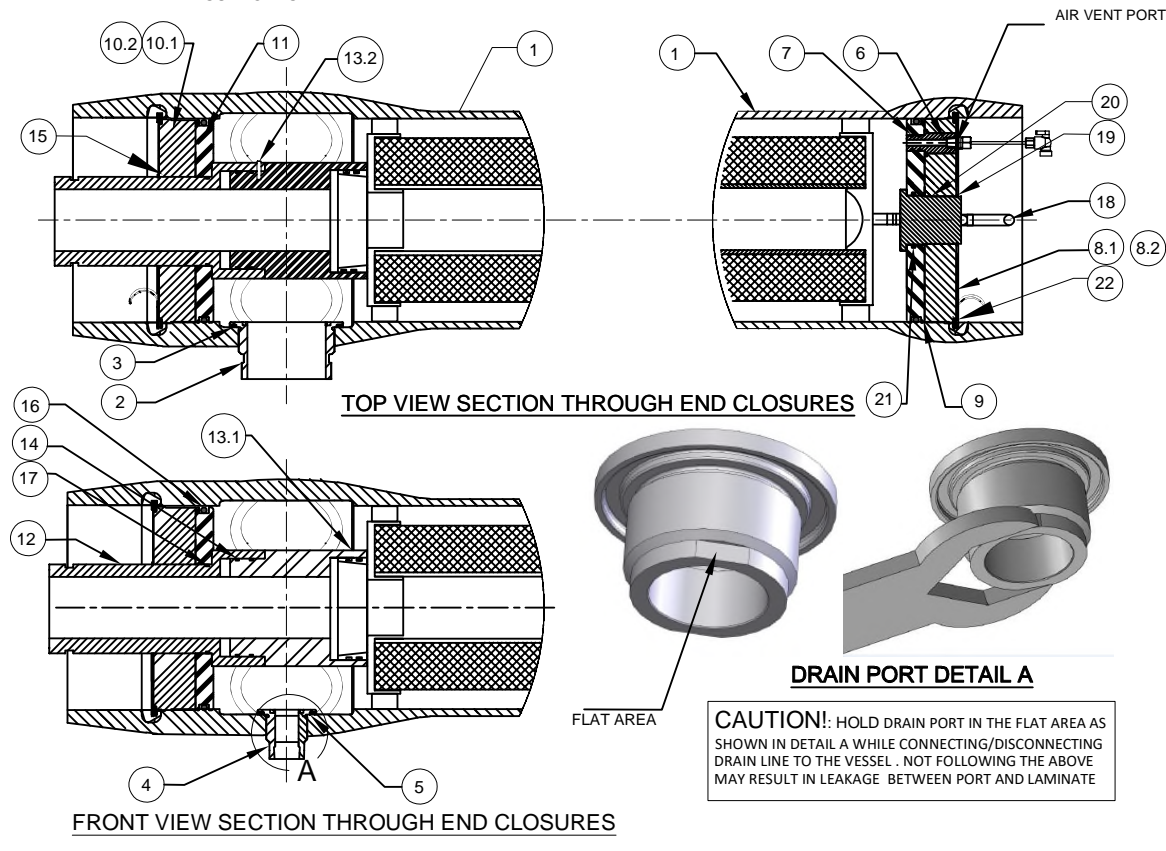

CAUTION: INCORRECT MANIFOLDING WILL CAUSE SEVERE LOCAL STRESS AROUND PORT AND MAY RESULT IN LEAKS AND PREMATURE FAILURE; TAKE EVERY PRECAUTION LISTED ON REVERSE. SEE INSTALLATION INSTRUCTIONS FOR FURTHER DETAILS

PORT SIZE CODE	
A	1" FNPT END
G	3" GROOVED END

NO. OF PORTS	PORT LOCATION	VESSEL QTY.

AIR VENT ASSEMBLY -17185			
ITEM	QUANTITY	PART NO.	DESCRIPTION
1	6" Long	RRS-01027	Tubing Blue
2	1	RRS-010013	Male Connector, Pipe 1/4" Tube 1/4"
3	1	RRS-01047	Compression nut 1/4"
4	1	RRS-01039	Ball Valve 1/4"
5	1	17194	Blind Plug 1/4"

Model	Approx Weight LB(KG)	Approx Weight With Filter LB(KG)
80CF30	64 (29)	80 (36)

**GENERAL NOTES:**  
 1. DIMENSION IN INCHES (MM APPROX.).  
 2. SHELL EXTERIOR COATED WITH WHITE RAL 9003, HIGH GLOSS POLYURETHANE PAINT.  
 3. NOT TO BE USED FOR CONSTRUCTION UNLESS CERTIFIED BY PENTAIR.  
 +OPTIONAL MATERIAL SELECTION AVAILABLE FOR 180°F APPLICATION ON SECOND PAGE.  
 \* ASME PARTS

THIS DOCUMENT AND THE INFORMATION CONTAINED HEREIN, ARE THE CONFIDENTIAL AND PROPRIETARY INFORMATION OF PENTAIR WATER INDIA PVT. LTD. PENTAIR WATER INDIA PVT. LTD. IS THE SOLE OWNER OF THE INFORMATION AND PROCESSES DEFINED HEREIN. THIS DOCUMENT, AND THE INFORMATION CONTAINED, MAY NOT BE DISCLOSED, REPRODUCED, DUPLICATED, USED, SOLD, PUBLISHED, COMMUNICATED OR OTHERWISE DISTRIBUTED, IN WHOLE OR IN PART, FOR ANY PURPOSE WITHOUT THE EXPRESS WRITTEN CONSENT OF PENTAIR WATER INDIA PVT. LTD. THIS DOCUMENT AND ANY COPIES, IN ALL APPLICABLE FORMATS, SHALL BE RETURNED TO PENTAIR WATER INDIA PVT. LTD. UPON REQUEST.

ALL INDICATED PENTAIR TRADEMARKS AND LOGOS ARE PROPERTY OF PENTAIR. THIRD PARTY REGISTERED AND UNREGISTERED TRADEMARKS AND LOGOS ARE PROPERTY OF THEIR RESPECTIVE OWNERS. BECAUSE WE ARE CONTINUOUSLY IMPROVING OUR PRODUCTS AND SERVICES, PENTAIR RESERVES THE RIGHT TO CHANGE SPECIFICATIONS WITHOUT PRIOR NOTICE. PENTAIR IS AN EQUAL OPPORTUNITY EMPLOYER.

© 2021 Pentair. All Rights Reserved.

**PENTAIR**  
CODELINE AQUALINE

**VERNA, GOA**  
INDIA

DRAWN BY: AND	DATE: 07MAR11	DRAWING DESCRIPTION: MODEL: 80CF30 SINGLE CARTRIDGE HOUSING	DRAWING NO.: 17038	REV.: Q
CHECKED BY: RD	DATE: 07MAR11	CUSTOMER NAME:	VESSEL MODEL: 80CF30-60 (CODED)	
APPROVED BY: RM	DATE: 07MAR11	PROJECT NAME:	TOTAL QTY: -	
ECN NO.: 6339	REV. DATE: 23JAN23	CUSTOMER P.O.#:	SIZE: A3	SCALE: NONE
			PAGE NO.: 01	OF 02

**RATING:**

DESIGN PRESSURE.....300 PSIG  
(2.07 MPa)  
MAX. OPERATING TEMP.....PVC / PET  
140°F/180°F  
(60°C/82°C)  
MIN. OPERATING TEMP.....20°F  
(-7°C)  
FACTORY TEST PRESSURE.....CE/ASME  
450PSIG/330 PSIG  
(3.10 MPa/2.28 MPa)  
QUALIFICATION PRESSURE.....1800 PSI  
(12.41 MPa)

**INTENDED USE:**

The AquaLine 80CF30 Fiberglass Pressure Vessel is designed for continuous, long term use as housing for AquaLine range of micro filtration elements.

The AquaLine 80CF30 is designed in accordance with the engineering standards of the Boiler and Pressure Vessel Code of the American Society of Mechanical Engineers (ASME) as per Section X Edition 2021 and all metallic parts are designed as per ASME Section VIII Division I Edition 2021.

At small additional cost vessels can be inspected during construction by an ASME Authorized Inspector and ASME Code stamped.

The AquaLine 80CF30 must be installed, operated and maintained in accordance with the listed precautions and good industrial practice to assure safe operation over a long service life.

The high performance Filament wound FRP shell must be allowed to expand under pressure; undue restraint at support points or piping connections can cause leaks to develop in the shell. This side-ported vessel requires special precautions in mounting and connection to piping so that the vessel will not be subjected to excessive stress due to bending moments acting at the side openings in the fiberglass shell. The end closure, incorporating close fitting, interlocking metal components, must be kept dry and free of corrosion; deterioration can lead to catastrophic mechanical failure of the head.

Pentair will assist the purchaser in determining the suitability of this standard vessel for their specific operating conditions. The final determination however, including evaluation of the standard material of construction for compatibility with the specific corrosive environment, shall be the responsibility of the purchaser. Alternate materials with enhanced corrosion resistance are available on special order.

Specifications are subject to change without notice.

**PRECAUTIONS:**

DO...read, understand and follow all instructions; failure to take every precaution will void warranty and may result in vessel failure

DO...mount the shell on horizontal members at span "S" using compliant vessel supports furnished; Shim saddles if required. Tighten hold down straps just snug.

DO...align and center side ports with the manifold header. Correct, causes of misalignment in a row of vessels connected to the same header

DO...use flexible type grooved-end pipe couplings, IPS grooved coupling or equal, at side ports; allow full, 0.125 inch gap between port and piping, and position piping to maximize flexibility of connection.

DO...provide flexibility in, and support for piping manifolds so that vessel can grow in length under pressure without undue restraint; provide additional flexible joints in large pipes leading to manifold header.

DO... Lubricate seals sparingly, using non-petroleum based lubricants, i.e. Glycerin or suitable lubricants.

DO...provide overpressure protection for vessel set at not more than 105% of design pressure

DO...inspect end closures regularly; replace components that have deteriorated and correct causes of corrosion

DO NOT...work on any component until first verifying that pressure is relieved from vessel

DO NOT...make rigid piping connections to ports or clamp vessel in any way that resists growth of fiberglass shell under pressure;

DO NOT...pressurize vessel until double-checking to verify that the Locking Ring is in place and fully seated.

DO NOT...operate vessel at pressure and temperature in excess of its rating.

DO NOT...tolerate leaks or allow end closures to be routinely wetted in any way

DO NOT...operate outside the pH range of 3-11.

**ORDERING:**

Using the chart below, please check the features you require and fax them with your purchase order to our customer service department for further processing. For optional materials and / or feature not listed below, please consult the factory for pricing and availability

**VESSEL LENGTH CODE**

**MODEL:** AquaLine 80CF30-60

**CERTIFICATION REQUIRED**

- Hydro testing at 1.1 times the design pressure.
  - In compliance with the ASME Sec X but not Code Stamped.
  - ASME Stamped and National Board Registered.

- Hydro testing at 1.5 times the design pressure.
  - CE Marked.

**HEAD ASSEMBLY MATERIAL SELECTION**

- Standard: For 140°F application, Engineering Thermoplastic components in PVC as per drawing on First page.**
- Option: For 180°F application, Engineering Thermoplastic components in PET as given below. (Please consult factory as these options will affect pricing and vessel lead time)

HEAD COMPONENTS FOR 180°F APPLICATION				
DWG REF	QTY	PART NUMBER	DESCRIPTION	MATERIAL
6	1	17433	1/4" FNPT Air Vent Port	SA-995 CD3MWCuN (J93380)
7	2	196208	1/4" Air Vent Port Seal	O - Ring - EPDM
8	1	194944	Bearing Plate Assembly Handle End	
8.1*	1	17179	Bearing Plate Handle End	SB-221 A96061-T6
8.2	1	17455	Danger Label Handle End	-
9	1	117007	Sealing Plate Handle end	Engineering Thermoplastic - Noryl.
10	1	194945	Bearing Plate Assembly Product end	
10.1*	1	17416	Bearing Plate Product end	SB-221 A96061-T6
10.2	1	17454	Danger Label Product End	-
11	1	17453	Sealing Plate Product end	Engineering Thermoplastic - PET.
12	1	17441	3" Product Port	SA-995 CD3MWCuN (J93380)
13.1	1	17444	Product Port Adapter	SA-995 CD3MWCuN (J93380)
13.2	1	17435	Product port holding pin	Engineering Thermoplastic
14	2	17164	Seal for Product Port Adapter	O - Ring-EPDM
15	1	17127	Product Port Retainer Ring	SA-479 316
16	2	196223	Head Seal	O - Ring - EPDM
17	1	17128	Product Port Seal	O - Ring - EPDM
18	1	17104	Handle Assembly	SA-479 316
19	1	45247	Plug Retainer Ring	Stainless Steel
20	1	17407	Plug	Engineering Thermoplastic - PET.
21	1	196215	Plug seal	O - Ring - EPDM

**FEED PORT CONFIGURATION**

Please fill out quantity for each configuration

- 1A 4G – Standard
- 1A 2G – (Optional)
- 1A 2G 4G – (Optional)

For complete information on proper use of the vessel  
Please refer to the AquaLine User Guide No 17456.

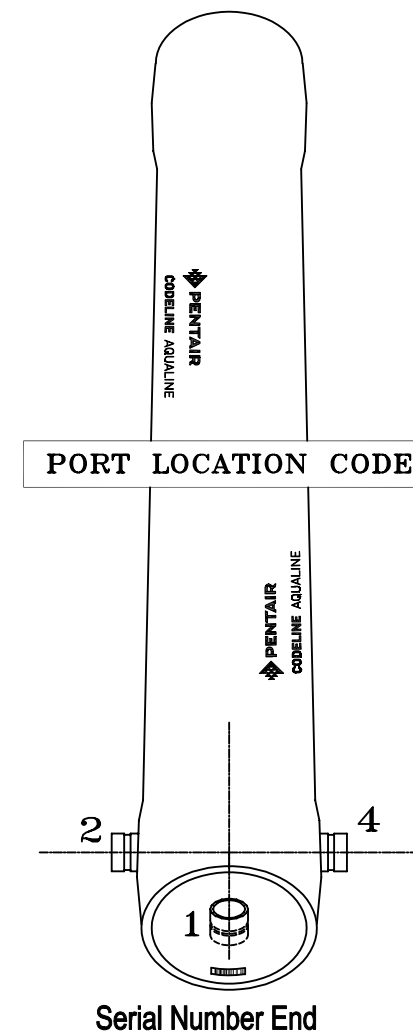

\* ASME PARTS

THIS DOCUMENT AND THE INFORMATION CONTAINED HEREIN, ARE THE CONFIDENTIAL AND PROPRIETARY INFORMATION OF PENTAIR WATER INDIA PVT. LTD. PENTAIR WATER INDIA PVT. LTD. IS THE SOLE OWNER OF THE INFORMATION AND PROCESSES DEFINED HEREIN. THIS DOCUMENT, AND THE INFORMATION CONTAINED, MAY NOT BE DISCLOSED, REPRODUCED, DUPLICATED, USED, SOLD, PUBLISHED, COMMUNICATED OR OTHERWISE DISTRIBUTED, IN WHOLE OR IN PART, FOR ANY PURPOSE WITHOUT THE EXPRESS WRITTEN CONSENT OF PENTAIR WATER INDIA PVT. LTD. THIS DOCUMENT AND ANY COPIES, IN ALL APPLICABLE FORMATS, SHALL BE RETURNED TO PENTAIR WATER INDIA PVT. LTD. UPON REQUEST.

ALL INDICATED PENTAIR TRADEMARKS AND LOGOS ARE PROPERTY OF PENTAIR. THIRD PARTY REGISTERED AND UNREGISTERED TRADEMARKS AND LOGOS ARE PROPERTY OF THEIR RESPECTIVE OWNERS. BECAUSE WE ARE CONTINUOUSLY IMPROVING OUR PRODUCTS AND SERVICES, PENTAIR RESERVES THE RIGHT TO CHANGE SPECIFICATIONS WITHOUT PRIOR NOTICE. PENTAIR IS AN EQUAL OPPORTUNITY EMPLOYER.

© 2021 Pentair. All Rights Reserved.



VERNA, GOA  
INDIA

DRAWN BY: AND	DRAWING DESCRIPTION: MODEL: 80CF30 SINGLE CARTRIDGE HOUSING	DRAWING NO.: 17038	REV.: Q
DATE: 07MAR11	CUSTOMER NAME: -	VESSEL MODEL: 80CF30-60 (CODED)	
CHECKED BY: RD	PROJECT NAME: -	TOTAL QTY: -	
DATE: 07MAR11	CUSTOMER P.O.#: -	SIZE: A3	SCALE: NONE
ECN NO.: 6339	REV. DATE: 23JAN23	PAGE NO.: 02 OF 02	